



Wind Turbines

Techs & Specs

- 1. Wind Turbines/Basics**
- 2. Designs**
- 3. 5 Enerji Advantages**
- 4. Turbine Design Examples**
- 5. Product Line**
- 6. Competition in the Market (Under 1 MW)**
- 7. Investment & Feasibility Examples**
- 8. 5 Enerji Production stage**



Enerji

- Engaged in the design and manufacture of power generation systems which utilize renewable energy sources.
- The only domestic manufacturer company who uses wind, solar, geothermal, biogas and biomass-based power plants project design and manufacture machines
- Creating product groups, acting responsive to people and the environment, which is contributes to the conservation of natural energy sources.
- Working without compromising on quality and reliability on their products and services.
- Aiming the satisfaction of our partners and customers and taking firm steps towards becoming a leading company in the sector.

1. Wind Turbines/Basics

- Wind Turbine is the general name of the systems where the wind power is transmitted to the blades and a generator that converts electrical energy.
- Newly generated electric power, by using an electronic circuit called an inverter, converts them to a standard network, or transferred to the grid.
- Wind turbines consists of the following five main parts
 - Blades
 - Generator
 - Invertor
 - Controlling & PLC
 - Groundwork & Tower



MERMERLER NANO
ÇEVRE TEKNOLOJİLERİ A.Ş.

2. Designs

- Wind turbines are designed according to vertical and horizontal wing types.
- Electric generator is an electric motor essentially works in reverse mode.
- Wind turbines are divided into two by the generator design
 - Permanent magnet generators
 - Hard-wound rotating magnet generators



MERMERLER NANO
ÇEVRE TEKNOLOJİLERİ A.Ş.



Horizontal Axis



Vertical Axis



MERMERLER NANO
ÇEVRE TEKNOLOJİLERİ A.Ş.



Rotating Magnet Rotor



Rotating Rotor with Windings

3. Advantages

- 5 Enerji wind turbines prefers horizontal axis blades and rotating magnet generators in their designs.
- Advantages of 5 Enerji Wind Turbines:
 - Uses domestically manufactured carbon fiber blades, specially designed for Turkey's environmental condition.
 - Produces highly strong parts which needs less service such as fixed windings.
 - Uses direct drive technology which reduces costs of maintenance encountered to others



MERMERLER NANO
ÇEVRE TEKNOLOJİLERİ A.Ş.

- Without using gear box, gains high efficiency with minimum torque
- Lower noise
- Easy to find spare parts because of the domestic manufacturing
- High efficiency with neodymium magnets
- Longer productivity periods because it starts with lower wind
- Longer warranty period with using less mechanical parts
- Trouble free control system with speed and temperature protection
- Advantage of selling energy to the state with higher prices, again because of domestic manufacturing



MERMERLER NANO
ÇEVRE TEKNOLOJİLERİ A.Ş.

4. Turbine Design Examples

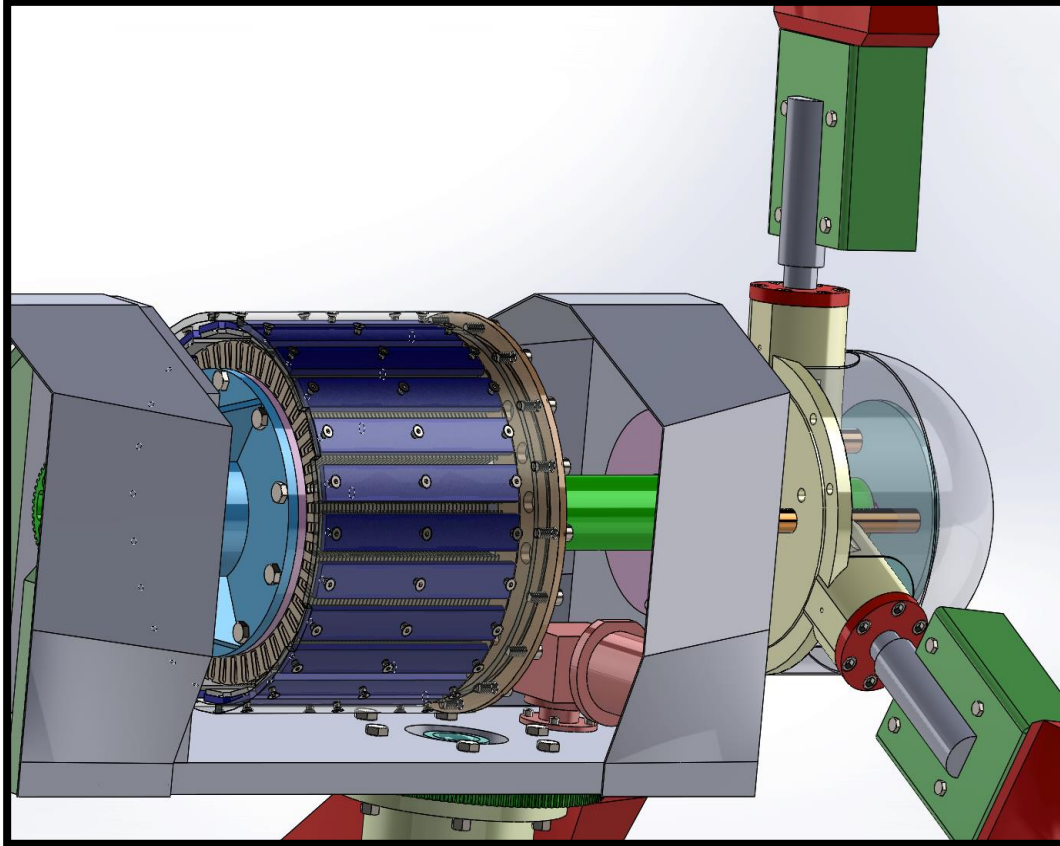

5.Product Line

Sistem Cinsi	Model	Güç	Kanat Yarı Çapı	Gerilim / Çıkış Gerilimi	Hız	Optimum Hız / Devir
		(W)	(m)	(Volt)	(m/sn)	(m/s) / (rpm)
KÜÇÜK ÖLÇEK RÜZGAR TÜRBİNİ SERİSİ						
OTONOM	5E-WT3 K	3000	1,65	(48)/220	3 – 25	12,5/250
ŞEBEKE BAĞLANTILI	5E-WT3.N	3000	1,65	(48)/380	3,5 – 25	12,5/250
OTONOM	5E-WT5.K	5000	1,65	(48)/220	3 – 25	12,5/250
ŞEBEKE BAĞLANTILI	5E-WT5.N	5000	1,65	(48)/380	3,5 – 25	12,5/250
OTONOM	5E-WT10.K	10.000	3,2	(48)/220	3 – 25	12,5/250
ŞEBEKE BAĞLANTILI	5E-WT10-N	10.000	3,2	(48)/380	3,5 – 25	12,5/250
ORTA ÖLÇEK RÜZGAR TÜRBİNİ SERİSİ						
Sistem Cinsi	Model	Güç	Kanat Yarı Çapı	Gerilim / Çıkış Gerilimi	Hız	Optimum Hız / Devir
		(W)	(m)	(Volt)	(m/sn)	(m/s) / (rpm)
ŞEBEKE BAĞLANTILI	5E-WT20-DS	20000	3-4	(400)/380	3 – 25	12,5/62,5
ŞEBEKE BAĞLANTILI	5E-WT30-DS	30000	4-5	(48)/380	3,5 – 25	12,5/62,5
ŞEBEKE BAĞLANTILI	5E-WT50-DS	50.000	5-6,5	(48)/380	3 – 25	12,5/62,5
ŞEBEKE BAĞLANTILI	5E-WT75-DS	75.000	5,5-8,5	(48)/380	3 – 25	12,5/62,5
ŞEBEKE BAĞLANTILI	5E-WT100-DS	100.000	6-9	(48)/380	3,5 – 25	12,5/62,5
ŞEBEKE BAĞLANTILI	5E-WT150-DS	150.000	9-13	(48)/380	3 – 25	12,5/62,5
ŞEBEKE BAĞLANTILI	5E-WT250-DS	250.000	13-16	(48)/380	3,5 – 25	12,5/40

6.Competition in the Market (Under 1 MW)

- Thousands of application for the licensed production considering the need for electricity in Turkey, with this wind energy potential is not surprising.
- On the other hand, neither high nor low power capacity turbine Brands formed in Turkey yet.
- That's why many low power capacity turbines imported but couldn't maintained in the market.
- Many domestic companies, who invested in wind turbines before the legal regulations couldn't survive in the process.



MERMERLER NANO
ÇEVRE TEKNOLOJİLERİ A.Ş.

- 5 Enerji, produced lean and sustainable model while all the other Brands left the market untrustable for the consumers in this period.
- With our efforts in prioritizing the domestic manufacturing, other companies started to invest in business, such as manufacturing domestic PLC cards and invertors.
- 5 Enerji is also the only company which uses all renewable energy sources like biogas, biogas, jeothermal and ofcourse sun.

7. How to calculate Characteristics of Investment Feasibility

- First of all, based on the received coordinates and statistical wind data provided from official sources, we calculate the annual productivity periods.
 - Adding the Low altitude and topographic variables we calculate the lapses.
 - With current electricity pricing listed by government we calculate the costs and saves <http://www.tedas.gov.tr/bilgibankasi/sayfalar/elektriktarifeleri.aspx>
 - We add guaranteed purchase support of the government for domestic production to the first 10 year plan.
 - We add the planned or unplanned off-period of the turbines to the list.
- As a result, After all these calculations, 5 Enerji wind turbines is the best choice**
With offering shorter refund in investment and long term efficiency in the domestic market



MERMERLER NANO
ÇEVRE TEKNOLOJİLERİ A.Ş.

TÜRKİYE RÜZGAR ENERJİSİ POTANSİYEL ATLASI

Rüzgar Hızı Haritası

100 m Yükseklikte Yıllık Ortalama

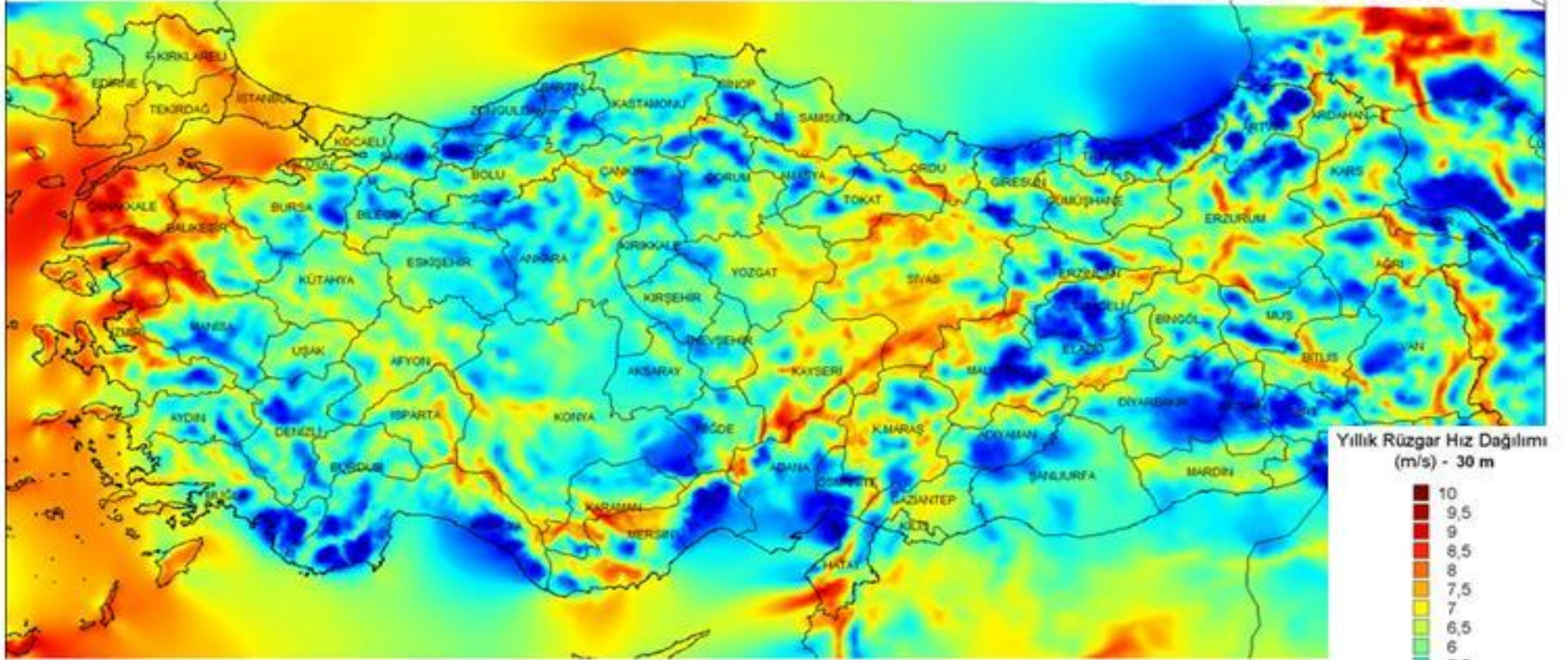



MERMERLER NANO
ÇEVRE TEKNOLOJİLERİ A.Ş.

Bölgelere Göre Türkiye Rüzgar Potansiyeli

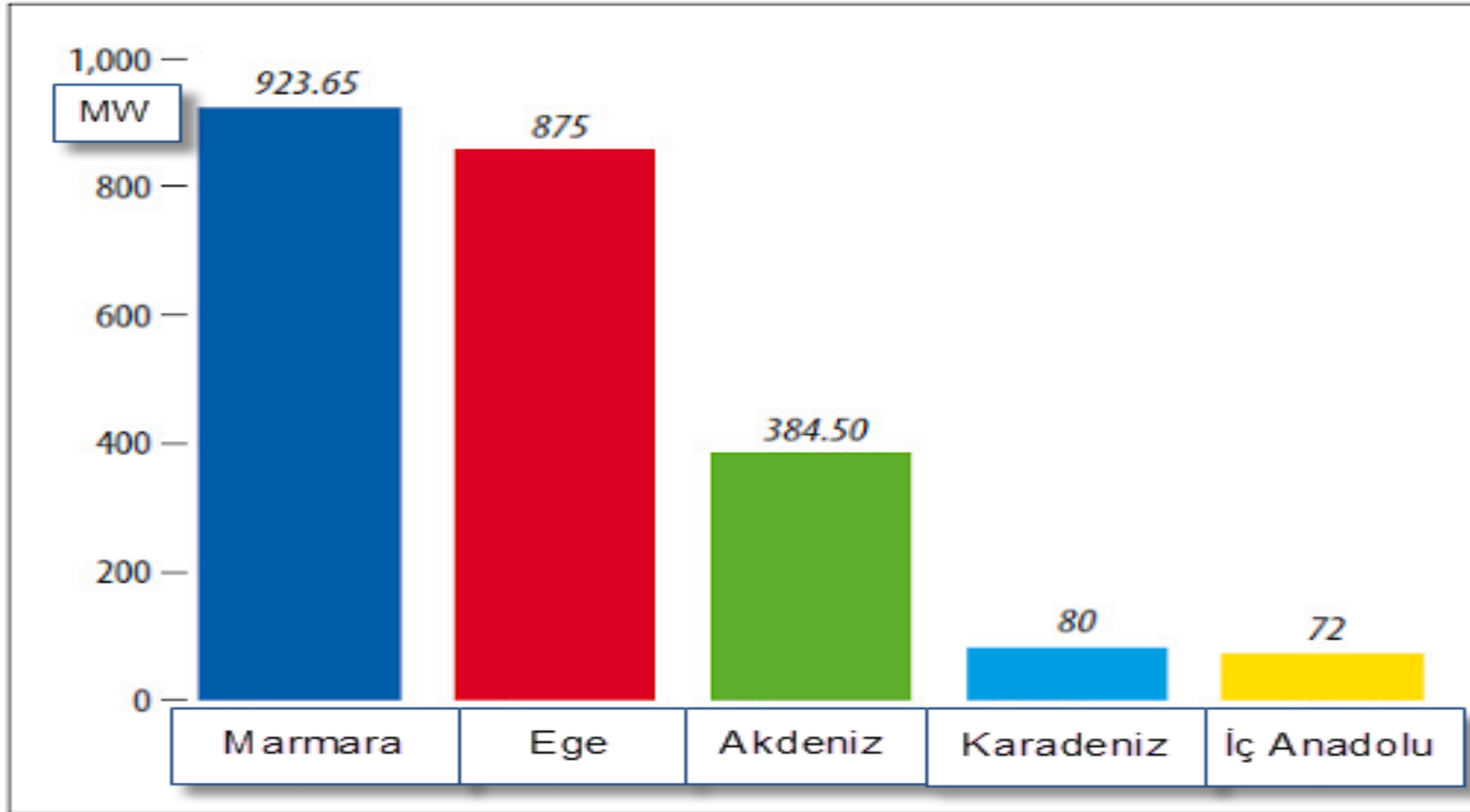

Source: NREL



MERMERLER NANO
ÇEVRE TEKNOLOJİLERİ A.Ş.

8. Production Stage



MERMERLER NANO
ÇEVRE TEKNOLOJİLERİ A.Ş.

Factory





MERMERLER NANO
ÇEVRE TEKNOLOJİLERİ A.Ş.





MERMERLER NANO
ÇEVRE TEKNOLOJİLERİ A.Ş.

Manufacturing





MERMERLER NANO
ÇEVRE TEKNOLOJİLERİ A.Ş.





MERMERLER NANO
ÇEVRE TEKNOLOJİLERİ A.Ş.



Blades

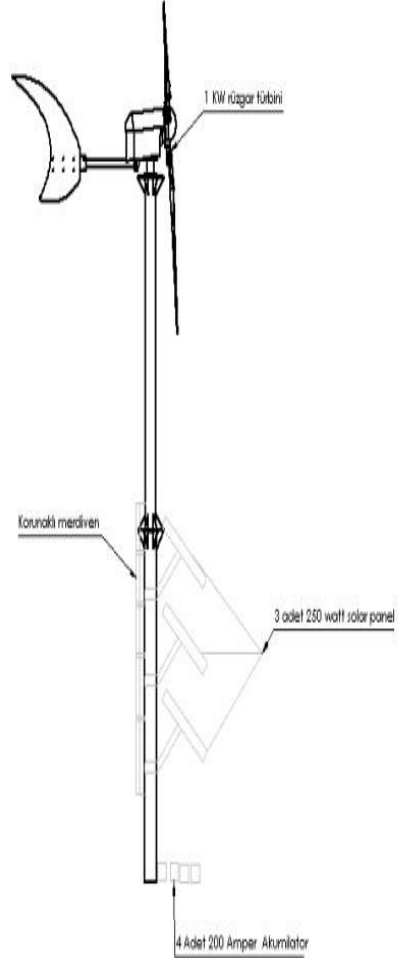



MERMERLER NANO
ÇEVRE TEKNOLOJİLERİ A.Ş.

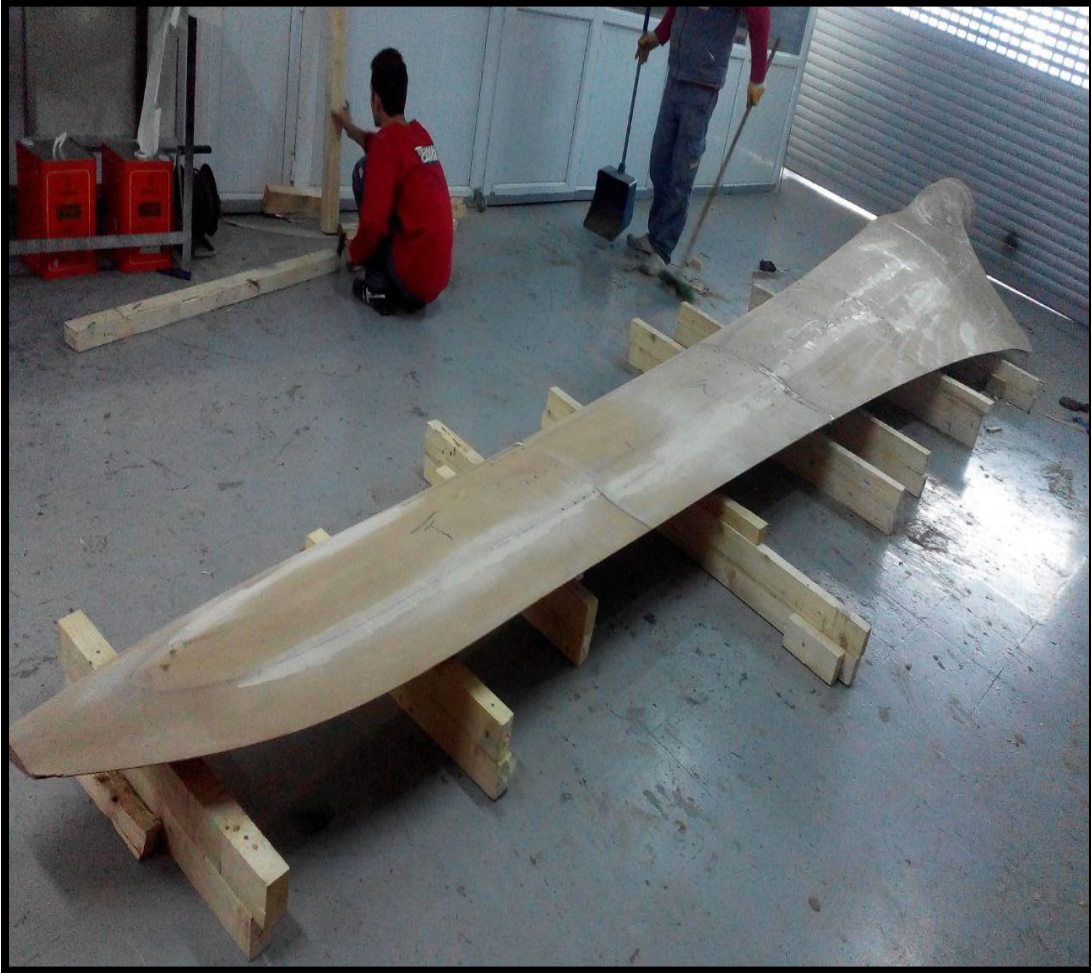



MERMERLER NANO
ÇEVRE TEKNOLOJİLERİ A.Ş.





MERMERLER NANO
ÇEVRE TEKNOLOJİLERİ A.Ş.





MERMERLER NANO
ÇEVRE TEKNOLOJİLERİ A.Ş.



Tower







MERMERLER NANO
ÇEVRE TEKNOLOJİLERİ A.Ş.





MERMERLER NANO
ÇEVRE TEKNOLOJİLERİ A.Ş.

Assembly





MERMERLER NANO
ÇEVRE TEKNOLOJİLERİ A.Ş.

On the Field





MERMERLER NANO
ÇEVRE TEKNOLOJİLERİ A.Ş.

Thanks

ZAFER MURAT MERMER

+90 554 394 5560

Contact :

www.mermerlernano.com